

## Model AFP-03Z-300 Z-Purge Unit

### DESCRIPTION

The AB-CO PURGE Model AFP-03Z-300 Purge and Pressurization System is a Z-Type system designed specifically for larger-sized electrical enclosures with volumes up to 300 cubic feet (8.5 cubic meters). As a Z-Type purge and pressurization system, the Model AFP-03Z-300 reduces the classification within the electrical enclosure used in a Class I, Division 2 (Groups A,B,C,D) and Class II, Division 2 (Groups F&G) hazardous environment from Division 2 to unclassified.

It supplies the enclosure with the proper amount of inert gas or clean instrument air which removes flammable gases and prevents the accumulation of ignitable mixtures within the respective protective enclosure. In addition, this AB-CO PURGE system is a very economical way to place unclassified equipment into a Division 2 hazardous location. The Model AFP-03Z-300 regulates and monitors the continuous flow (0.5 to 40 SCFH) of inert gas or clean instrument air into the electrical enclosure which can eliminate problems like heat, moisture, dust and corrosion within your enclosure. The purge and pressurization system features a standard fast purge safety feature which will exchange four volumes of inert gas or instrument air in times consistent with NFPA 496. The times are indicated on the front control panel.

This unit is ruggedly constructed of a SS control panel and 1/2-inch O.D. 304 SS tubing.

It is also supplied with a vent (Model AV-2BG) that is used with the integral relief valve. If required, an explosion proof pressure switch (Models DP-1A, DP-1B, or DP-1C) is available which can provide either audio and/or visual indication of a loss of purge (see details on specification section of this data sheet).

A heavy gauge stainless steel universal mounting bracket, a 1/2-inch tube fitting for the cabinet, and an enclosure warning label are supplied with this unit. The installer is responsible for providing the 3/8-inch tubing from the Model AFP-03Z-300 to the electrical enclosure.

This unit is certified by UL and approved by FM to meet the NFPA 496 Standard (Standard for Purged and Pressurized Enclosures for Electrical Equipment).

Note: See Model AFP-01Z-15 or Model AFP-02Z-75 for Z-Type purge systems designed for smaller size enclosures.

### FEATURES

- Z-Type Purge and Pressurization System
- UL, FM certifications
- Meets requirements of NFPA 496 Standard
- Maximum enclosure volume = 300 cubic ft. (8.5 cubic meters)
- Fast purge capability (times displayed on front display panel)
- Stainless Steel construction
- Easy to install
- Easy to use
- Vent included
- Universal mounting bracket
- Use with any enclosure shape
- Explosion proof pressure switch for remote alarm
- Mounting bracket, enclosure fittings, and warning label(s) included

### BENEFITS

- Reduces classification in a hazardous environment from Class I or Class II, Division 2 to unclassified
- Excellent safety margin
- Cost effective solution
- Extends equipment life
- Reduces heat build-up
- Eliminates dust contamination
- Prevents moisture and corrosion



# Model AFP-03Z-300

## NFPA Purge Type:

### Z-Type

Enables use of unclassified equipment in Class I, Division 2 (Groups A,B,C,D) and Class II, Division 2 (Groups F&G) hazardous location.

## Hazardous Location:

### Class I, Division 2, Groups A, B, C, D

### Class II, Division 2, Groups F&G

See "Pressure Switch" specification. Using the recommended pressure switch affects the applicable Group.

*Note: Not approved for Group E -Aluminum, Magnesium, and Alloy Dust.*

## Electrical Enclosure Content:

### Unclassified

## Pressure Indicator:

Analog meter with safe working pressure range indicated as 0.15 - 0.35 inches of water.

Pressure reading scale graduated in increments of 0 - 0.05 inches of water.

## Enclosure Volume (Maximum):

75 - 300 Cubic Feet (2.12 - 8.5 cubic meters)

## Gas/Air Supply:

### Supply Pressure:

Maximum of 195 psig (100 psig is preferable)

Must be NON-EXPLOSIVE dry, non-corrosive and filtered to 30 micron.

## Fast Purge:

**Output flow:** 46 SCFM (Standard Cubic Feet Per Minute).

### Minimum Purge Cycle Time:

1 minute/10 cubic feet or enclosure volume.

(for enclosures with motors, generators, or other electrical machinery: 1 minute per 4.0 cu. ft. of enclosure volume)

**Maximum exchange pressure:** 3 - 5 inches water.

Fast Purge units are leakage compensated by providing high air/inert gas volumes to quickly purge hazardous gas from the electrical enclosure and then providing lower volumes sufficient to maintain a pressure inside the enclosure that is higher than the surrounding hazardous environment - thus compensating for leaks from the enclosure.

## Inlet Flow Rate:

80 SCFM (Standard Cubic Feet Per Minute)

## Continuous Flow Rate:

(Same as "Standard Maintenance Flow Rate)

0.5 - 40 SCFH (Standard Cubic Feet Per Hour)

## Relief Valve (Required):

### Model AV-2BG-T (Top Mount)

See AV-2BG-T in Accessories Section.

### Model AV-2BG-S (Side Mount)

See AV-2BG-S in Accessories Section.

## Mechanical Connections:

**Integral Tubing:** 0.5 inch OD x 0.035 inch wall SS.

**Supply fitting to Purge/Pressurization System:** 0.375 Inch FNPT.

### Inlet to Purge/Pressurization System:

0.5 inch SS tube fitting. For 0.5 inch OD x 0.035 inch wall.

### Outlet from Purge Pressurization System to Electrical

**Enclosure:** 0.5 inch SS tube fitting. For 0.375 inch OD x 0.5 inch wall.

**Reference line between pressure switch DP-1A, DP-1B, or DP-1C) and enclosure:** 0.25 inch SS tube fittings.

## Mechanical Connections (continued):

### Enclosure fittings:

0.5 inch SS tube fittings for both input and output. Fittings are supplied with the unit. Customer to supply tubing for connection to and from enclosure.

## Construction:

### One-piece front control panel

12 inches wide x 14 inches high, 14 Gauge SS, #4 finish with easy-to-read instructions and indicators on control panel. The instructions are acid etched and printed with UV inhibited ink.

## Mounting Bracket:

### External mount

(Universal for mounting to electrical enclosure - right side, left side, top, or bottom). 14 Gauge SS, #4 finish (Location is at the discretion of the customer).

## Weight:

8 lbs.

(11 lbs. with explosion proof pressure switch)

## Enclosure Warning Label(s):

### Adhesive label(s) supplied with each unit

Mounting location on the electrical enclosure is at the discretion of the customer. (Note: French language label(s) added for Canadian applications)

## Pressure Switch

(Recommended for remote visual and/or audio Alarm Capability):

### DP-1A (Internal mechanical diaphragm type)

*Explosion Proof.*

*Class I, Division 1, Groups C & D.*

*Class II, Division 2, Groups F & G.*

*No Input Power Required.*

*Output Signal From:*

*Form C Relay, Single-Pole Double-Throw Switch Type.*

*Three screw-type electrical Connection*

*(Common, Normally Open, Normally Closed).*

*Screw-type Setpoint Adjustment on top of housing.*

### DP-1B (Internal Hall Effect sensor)

*Explosion Proof and Flameproof.*

*Class I, Division 1, Groups A, B, C & D.*

*Class II, Division 2, Groups F & G.*

*Input Power: 24 VDC Power.*

*Output Signal From:*

*Form C Relay, Single-Pole Double-Throw Switch Type.*

*Five screw-type electrical Connection.*

*(Two of power plus Common, Normally Open, Normally Closed).*

*Screw-type Setpoint Adjustment on top of housing.*

### DP-1C (Internal Hall Effect sensor)

*Explosion Proof and Flameproof.*

*Class I, Division 1, Groups A, B, C & D.*

*Class II, Division 2, Groups F & G.*

*Input Power: 120 VAC Power.*

*Output Signal From:*

*Form C Relay, Single-Pole Double-Throw Switch Type.*

*Five screw-type electrical Connection.*

*(Two of power plus Common, Normally Open, Normally Closed).*

*Screw-type Setpoint Adjustment on top of housing.*

## Certifications:



# Model AFP-03Z-300

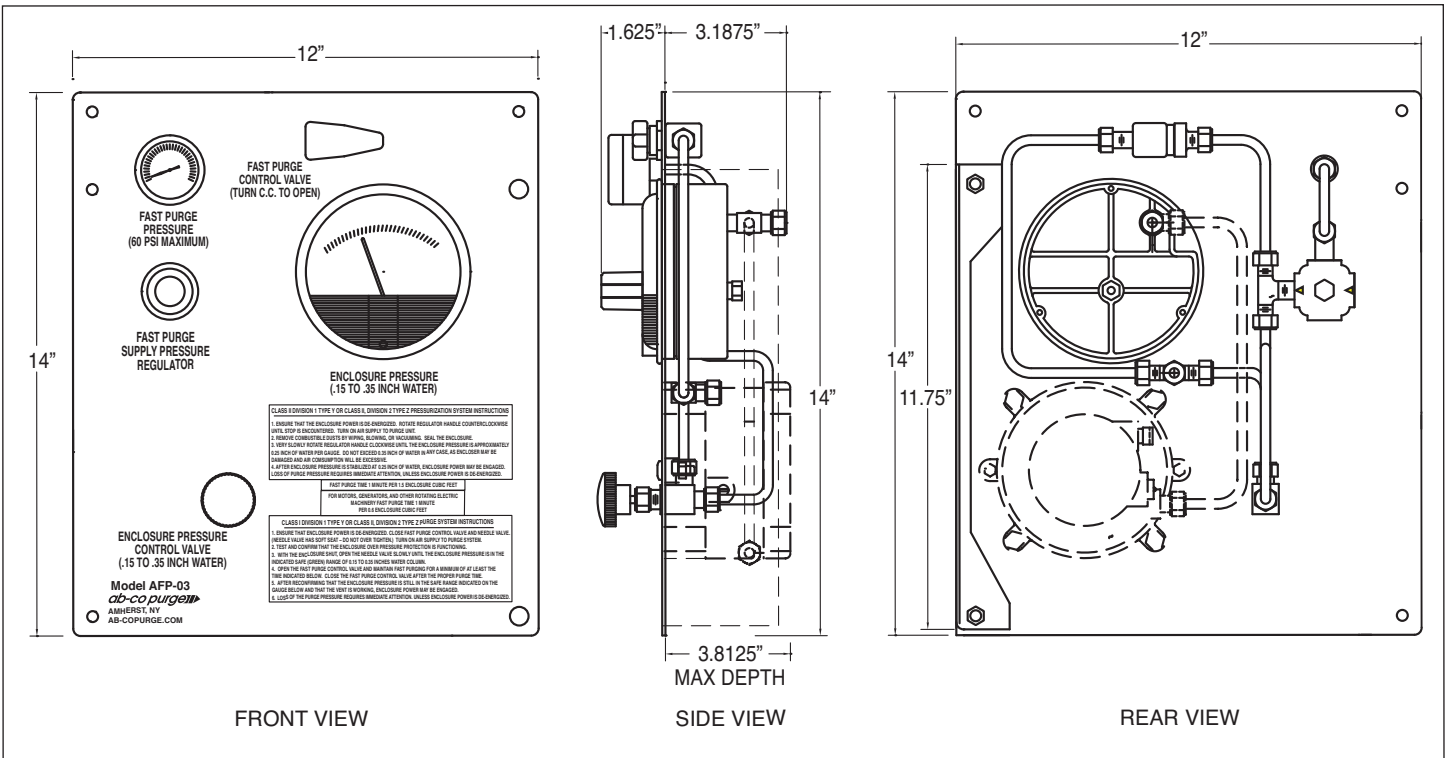

## Product Configuration Code

AFP-03 Z—300————

- 1 = UL Certified (US)\*
- 2 = UL Certified (Canada)\*
- 3 = FM Approved

- 2T = AV-2BG-T = Top Mount Vent
- 2S = AV-2BG-S = Side Mount Vent

- A = DP-1A Pressure Switch (Mechanical)
- B = DP-1B Pressure Switch (Electronic - 24 VDC)
- C = DP-1C Pressure Switch (Electronic - 120VAC)
- D = DP-1D Pressure Switch (Electronic - 240VAC)
- 0 = No Pressure Switch

\*UL Certified products require a DP-1A, DP-1B, DP-1C, or DP-1D pressure switch.

Model AFP-03

300 Cubic Ft. (Max. Enclosure Volume)... For Class I, Div. 2, Groups A,B,C,D  
 For Class II, Div. 2, Groups F&G

Z = Type-Z Purge and Pressurization System

**MODIFICATIONS:** We realize applications may vary and as such our designs are somewhat flexible. Options are available. Specifications on this datasheet represent the standard configuration only. Product and company names listed are trademarks of their respective companies. Specifications subject to change without notice.

**WARRANTY:** ab-co purge, LLC warrants that its product shall be free from defective workmanship and/or material for a twelve month period from the date of shipment, provided that ab-co purge, LLC's obligation hereunder shall be limited to correcting any defective material FOB our factory. No allowance will be made for any expenses incurred for correcting any defective workmanship and/or material without written consent by ab-co purge, LLC. This warranty is in lieu of all other warranties expressed or implied.



Due to the nature of technology, changes are inevitable.  
 For latest technical specifications, see our website.

Contact US  
 Tel: 716.500.abco